



Advanced Mobile System built to go wherever you need it, bringing smiles all of the way.



# A flexible and compact sized digital portable with big performance FDR Go is exactly what your portable exams need.

FDR Go introduces mobile exams with Fujifilm's trademark image quality and dose performance.

- A reliable, high performing 32kW portable system
- Integrated Console Advance speed and ease of use
- FDR D-EVO detectors with Patented ISS
- Dynamic Visualization Image Optimization

At the bedside, in the OR, ED, ICU, NICU or anywhere in between, FDR Go is sure to bring smiles every step of the way.



## Highly mobile

- **Lightweight and Compact**  
The lightweight, compact chassis size provides superb maneuverability even in tightest spaces.
- **Easy and Safe Travel**  
The system's dual motor drive provides smoother, easy steering and quiet travel. Travel speed is programmable for preferred maneuverability, acceleration and steering control. Fail safe drive handle automatically stops system when handle is released. Touch sensing safety bumper stops movement and signals user when contact is sensed.



- **"Inch-mover"**  
controls on the collimator slowly move system forward or backward for precise bedside positioning without having to return to the drive handle.



- **Comfortable Safe Storage**  
Storage area holds detector(s), grid(s) and spare batteries. Detector bin features a clever shock absorbing holder.



## Suitable for various situations

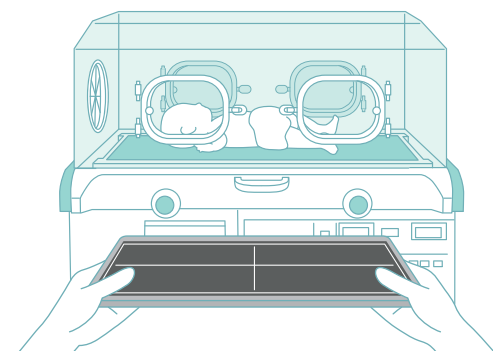

At the time of FDR Go's introduction, it is possible to select cassettes that suit the purpose. Carrying multiple cassettes, it allows various types to be used during a round. The combination with C24i enables examinations of babies in incubators.



## New CONSOLE ADVANCE with enhanced functions

The sophisticated design of the GUI contributes to the safe, comfortable and efficient performance of all radiographic examinations

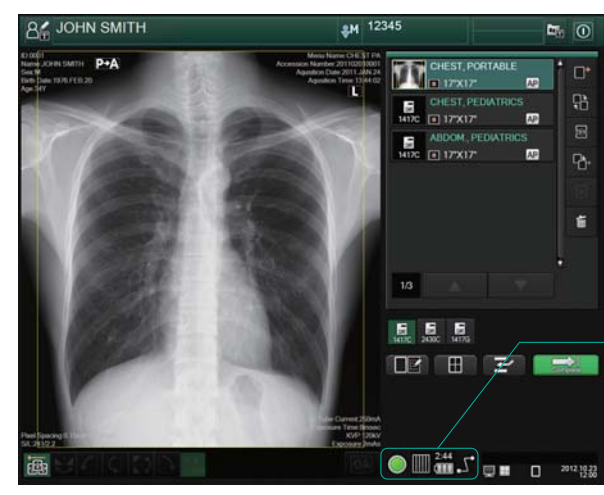

In addition to the familiar basic operation, new gradation design monitor and the intuitive arrangement of operation buttons make it possible to check and confirm information quickly and accurately. The image display area on the display monitor is larger, and enables easy checking of diagnostic images. An optional touch panel monitor ensures quick and accurate operation.



**Status display for D-EVO**  
The icons for the D-EVO are a new feature. When D-EVO is used it is possible to confirm its status; charge level, WiFi connection etc.



## Offers high quality image while using low dosage

- **ISS technology**  
"ISS technology" sees the TFT sensor placed in front of the scintillation layer instead of its traditional position behind it. This technology permits a higher resolution image and reduced doses.

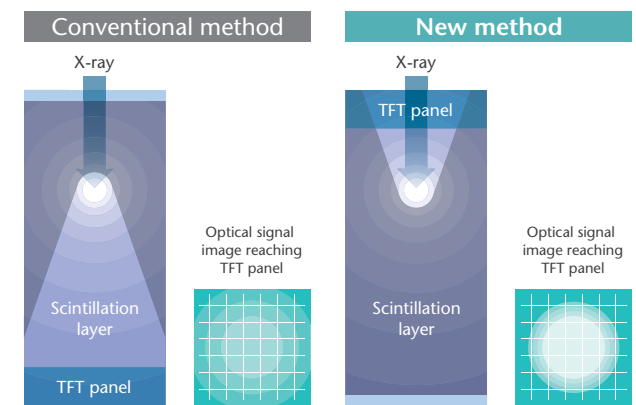

- **Dynamic visualization**  
Constantly endeavoring to provide the highest image quality, Fujifilm offers a proprietary technology to produce the optimal image for each examination. With the enhanced visibility achieved by this technology, information in greater detail can be obtained from images.

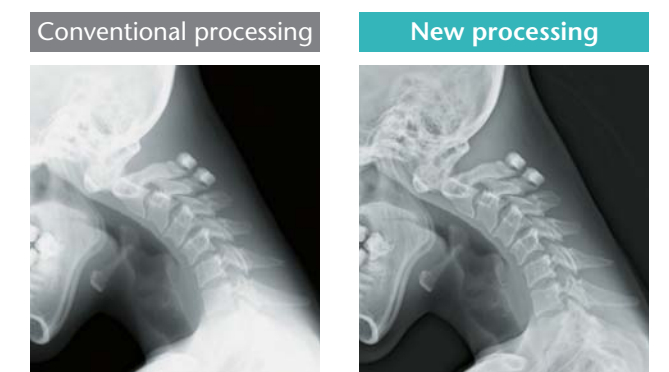



### Dimensions

Unit mm

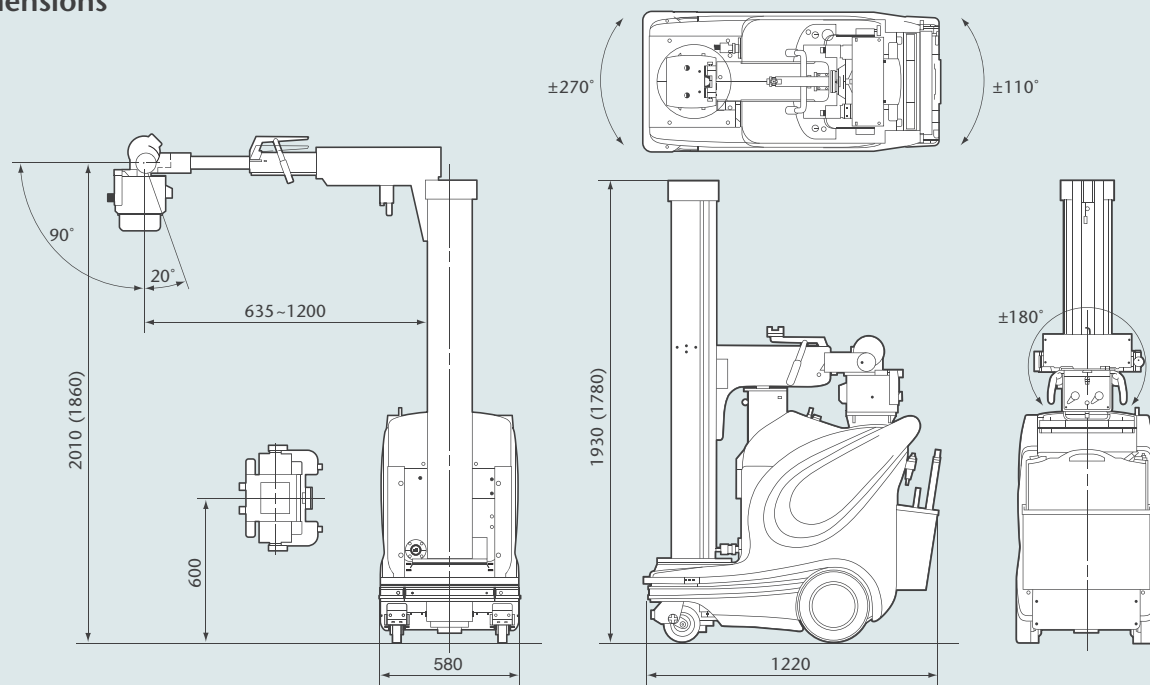

Values shown in ( ) are for Type S.

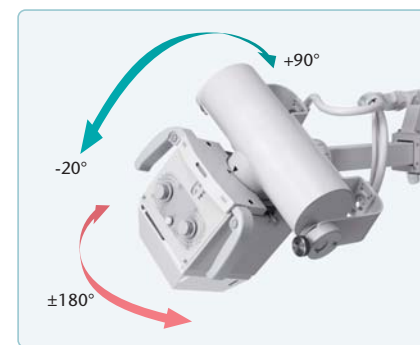
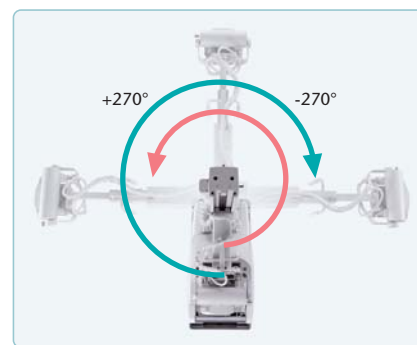
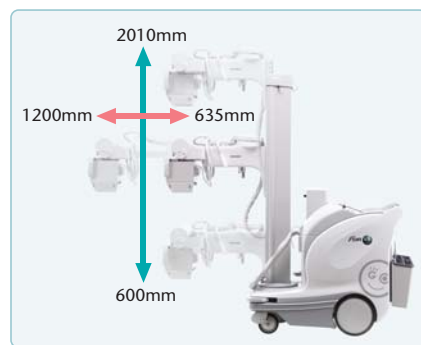

### FDR Go Specifications

<b>MODEL :</b>	FDR Go	<b>X-ray tube :</b>	<ul style="list-style-type: none"> <li>•Nominal Focal spot size: 0.7/1.3 mm (0.02"/0.05")</li> <li>•Maximum anode heat capacity: 210kJ (300kHU)</li> <li>•Target angle: 16 degrees</li> </ul>
<b>Power supply :</b>	100/110/120/200/220/230/240 V AC, Single phase: 50-60Hz	<b>Total Width :</b>	580 mm (22.8")
<b>Charger :</b>	Power consumption 1.0 kVA	<b>Total Length :</b>	1220 mm (48.0")
<b>X-ray output :</b>	<ul style="list-style-type: none"> <li>•Max. rating: 32kW (100kV, 320 mA, 20 ms / 80 kV, 400 mA, 20 ms)</li> <li>•Tube voltage: 40 - 133 kV in 1kV steps</li> <li>•Tube Current: Max 400mA (133 kV, 200 mA/400 mA, 80 kV)</li> </ul>	<b>Height of Column :</b>	Type S: 1780 mm (70.1") Type T: 1930 mm (76.0")
		<b>Weight :</b>	460 kg (1014 lbs)
		<b>Maximum Travel Speed :</b>	Approx. 5 km/h (may vary depending on condition)

### D-EVO Series Specifications

	FDR D-EVO plus C24i	FDR D-EVO G35i	FDR D-EVO plus C35i	FDR D-EVO G43i
<b>Scintillator</b>	CsI (Cesium iodide)	GOS (Gadolinium oxysulfide)	CsI (Cesium iodide)	GOS (Gadolinium oxysulfide)
<b>Detector external size</b>	328 × 268 × 15mm (Approx.) [13" × 11" × 0.6"]	460 × 384 × 15mm (Approx.) [18" × 15" × 0.6"]	460 × 384 × 15mm (Approx.) [18" × 15" × 0.6"]	460 × 460 × 15mm (Approx.) [18" × 18" × 0.6"]
<b>Weight</b>	1.9kg [4lbs.] (including battery)	3.2kg [7lbs.] (including battery)	3.6kg [8lbs.] (including battery)	4.0kg [9lbs.] (including battery)

•Specifications are subject to change without notice. •All brand names or trademarks are the property of their respective owners.  
•All products require the regulatory approval of the importing country. •For details on their availability, contact our local representative.



Advanced Mobile System built to go wherever you need it, bringing smiles all of the way.

