

Dimensions

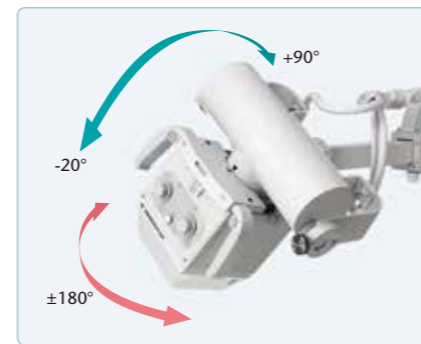
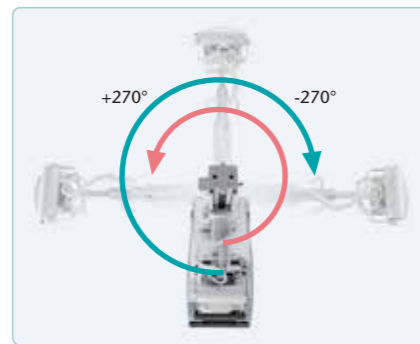
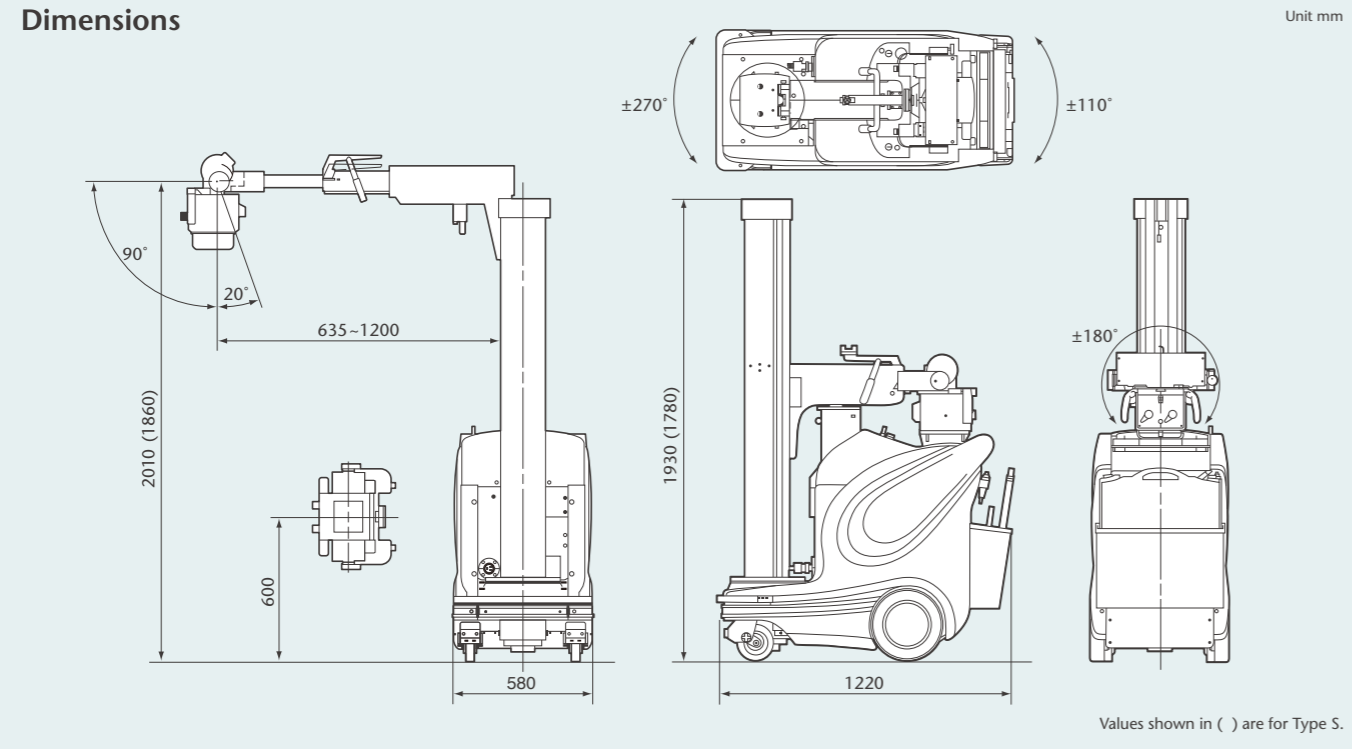

FDR Go Specifications

MODEL :	FDR Go	X-ray tube :	<ul style="list-style-type: none"> •Nominal Focal spot size: 0.7/1.3 mm (0.02"/0.05") •Maximum anode heat capacity: 210 kJ (300 kHU) •Target angle: 16 degrees
Power supply :	100/110/120/200/220/230/240 V AC, Single phase: 50-60Hz	Total Width :	580 mm (22.8")
Charger :	Power consumption 1.0 kVA	Total Length :	1220 mm (48.0")
X-ray output :	<ul style="list-style-type: none"> •Max. rating: 32kW (100 kV, 320 mA, 20 ms / 80 kV, 400 mA, 20 ms) •Tube voltage: 40 - 133 kV in 1 kV steps •Tube Current: Max 400 mA (133 kV, 200 mA / 400 mA, 80 kV) 	Height of Column :	Type S: 1780 mm (70.1") Type T: 1930 mm (76.0")
		Weight :	460 kg (1014 lbs)
		Maximum Travel Speed :	Approx. 5 km/h (may vary depending on condition)

D-EVOII Series Specifications

	D-EVOII C24	D-EVOII C35	D-EVOII G35	D-EVOII C43	D-EVOII G43
Scintillator	CsI (Cesium iodide)	CsI (Cesium iodide)	GOS (Gadolinium oxysulfide)	CsI (Cesium iodide)	GOS (Gadolinium oxysulfide)
Detector external size	328 × 268 × 15 mm (Approx.) [12.9" × 10.6" × 0.6"]	460 × 384 × 15 mm (Approx.) [18" × 15" × 0.6"]	460 × 384 × 15 mm (Approx.) [18" × 15" × 0.6"]	460 × 460 × 15 mm (Approx.) [18" × 18" × 0.6"]	460 × 460 × 15 mm (Approx.) [18" × 18" × 0.6"]
Weight	Approx. 1.9kg [4lbs.] (including battery)	Approx. 2.6kg [5.7lbs.] (including battery)	Approx. 2.6kg [5.7lbs.] (including battery)	Approx. 3.2kg [7.1lbs.] (including battery)	Approx. 3.2kg [7.1lbs.] (including battery)

•Specifications are subject to change without notice. •All brand names or trademarks are the property of their respective owners.
•All products require the regulatory approval of the importing country. •For details on their availability, contact our local representative.



Advanced Mobile Imaging- Go wherever you like, whenever you need.



A high performance yet flexible and compact digital portable, the FDR Go offers exactly what you need for your mobile exams.

The FDR Go brings with it mobile exams featuring Fujifilm's trademark image quality and dose performance.

- A reliable, high performance 32kW mobile system
- Speed and ease of use with the integrated Console Advance
- A super-lightweight FPD that is clean, waterproof, and robust
- New image processing technology "Virtual Grid"

At the bedside, in the OR, ED, ICU, NICU or anywhere in between, FDR Go is sure to bring smiles every step of the way.



Highly mobile

Lightweight and Compact

The lightweight, compact chassis ensures superb maneuverability even in the tightest of spaces.

Easy and Safe Travel

The system's dual motor drive provides smooth, easy steering and quiet travel. The travel speed can be adjusted to match the preferred maneuverability, acceleration and steering control. A fail safe drive handle automatically stops system movement when the handle is released, while the collision-sensing safety bumper stops movement and signals user when contact is detected.



"Inch-mover"

Controls on the collimator slowly move the system forward or backward, allowing precise bedside positioning without having to return to the drive handle.



Comfortable Safe Storage

A custom designed storage area holds detectors, grids and spare batteries. The detector bin features a clever shock absorbing holder.



Adaptable to the imaging environment

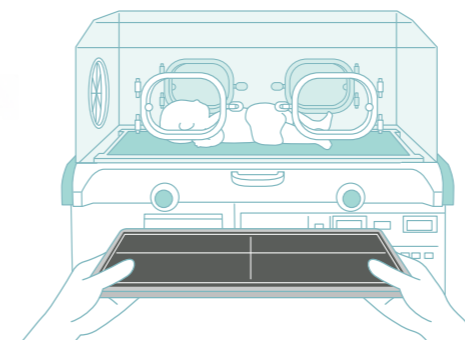

A range of DR detectors are available. Multiple panels can be carried on the system simultaneously, allowing the user the flexibility to change techniques mid-round. Neonatal examinations in incubators are simplified by the use of the C24.



CONSOLE ADVANCE with enhanced mobile workflow

The sophisticated design of the GUI contributes to the safe, comfortable and efficient execution of all portable examinations

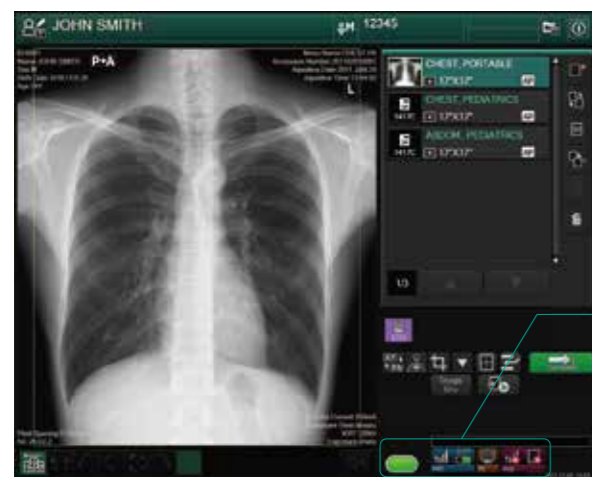

Combining the already familiar console advance workflow with a new color scheme and intuitive screen layout makes it possible to check and confirm study information quickly and accurately. The image display area on the monitor is now larger, allowing for easy review of diagnostic images, while an optional touch panel monitor ensures quick and accurate operation.



Status display for D-EVO II

System display icons for the D-EVO II are newly added. This makes it possible to verify the panel status at any time; including remaining charge level, WiFi connection etc.

New Image Processing Technology "Virtual Grid" *

* Option

Improving image contrast through the removal of scattered radiation

This newly developed "scattered radiation estimation technology" calculates and removes scattered radiation signal. Using this method the contrast of every image is automatically optimized; minimizing the impact of excess scatter caused by factors as diverse as patient physique, imaging region and imaging conditions (X-ray intensity, dose, etc.)



Contrast adjustment parameters in accordance with preferred grid type

Multiple simulated grid types are available. Image contrast is automatically adjusted equivalent to the preferred grid type.

